

Extraíble de armario alto Pleno Maxi

Armario alto con el máximo aprovechamiento del espacio, cómodo acceso y gran claridad organizativa para muebles con puertas con bisagras, disponible en dos versiones con diferente división de estantes



Al abrir la puerta, se puede ver claramente la totalidad del contenido porque este se desplaza saliendo del mueble.

Pleno Maxi aprovecha al máximo el espacio de almacenamiento disponible en altura y anchura para ofrecerle la máxima claridad organizativa. Cuando se abre la puerta, los estantes se deslizan hacia fuera y se puede ver dónde está todo inmediatamente. Además, la cómoda versión Plus distribuye la zona superior entre la puerta y la estructura del mueble, de modo que se puede alcanzar cómodamente incluso el objeto que se encuentre más al fondo del armario. Pleno Maxi es ideal como despensa central o como armario completo de vajilla.

Datos técnicos

Línea de diseño	Liro
Frontales sin tiradores	opcional
Sin barreras	sí
Softclose integrado	no
Softopen integrado	sí
Tipo	1300/1600/1900
Ancho de mueble mín. (EB)	450/600 mm
Modelo	izquierdo/derecho
Color	blanco/plateado/antracita
Capacidad de carga	0-78 kg
Ancho interior mín. (LB)	404/554 mm
Profundidad interior mín. (LT)	500 mm
Altura interior mín. (LH)	1150/1450/1800 mm

Características y ventajas

- Vista general completa y acceso libre inmediatamente después de la apertura la puerta
- Adecuado como armario doble sin tabique para despensa central
- Máximo aprovechamiento del espacio en anchura, profundidad y altura.
- La mejor accesibilidad a todos los rincones, incluso a los que están más arriba, gracias a los estantes extraídos ya la profundidad del estante dividida en la zona superior (versión Plus)
- Accesorios opcionales para un uso personalizado de los estantes

Características técnicas

- Estantes de altura ajustable sin herramientas (a excepción de los estantes para puertas en la versión Plus).
- Opcionalmente con sistema 'pulsar para abrir' para frontales sin tirador
- Tecnología sin mantenimiento
- Independiente de la altura, la anchura y la profundidad gracias al montaje-base-lado en un solo lado
- Montaje sencillo y rápido
- Adecuado para bisagras estándar con un ángulo de apertura de 110°



PLENO MAXI

Hochschrankauszug für Möbel mit scharnierten Türen
 Extension d'armoire haute pour meubles avec portes à charnières
 Larder pull-out for units with hinged doors

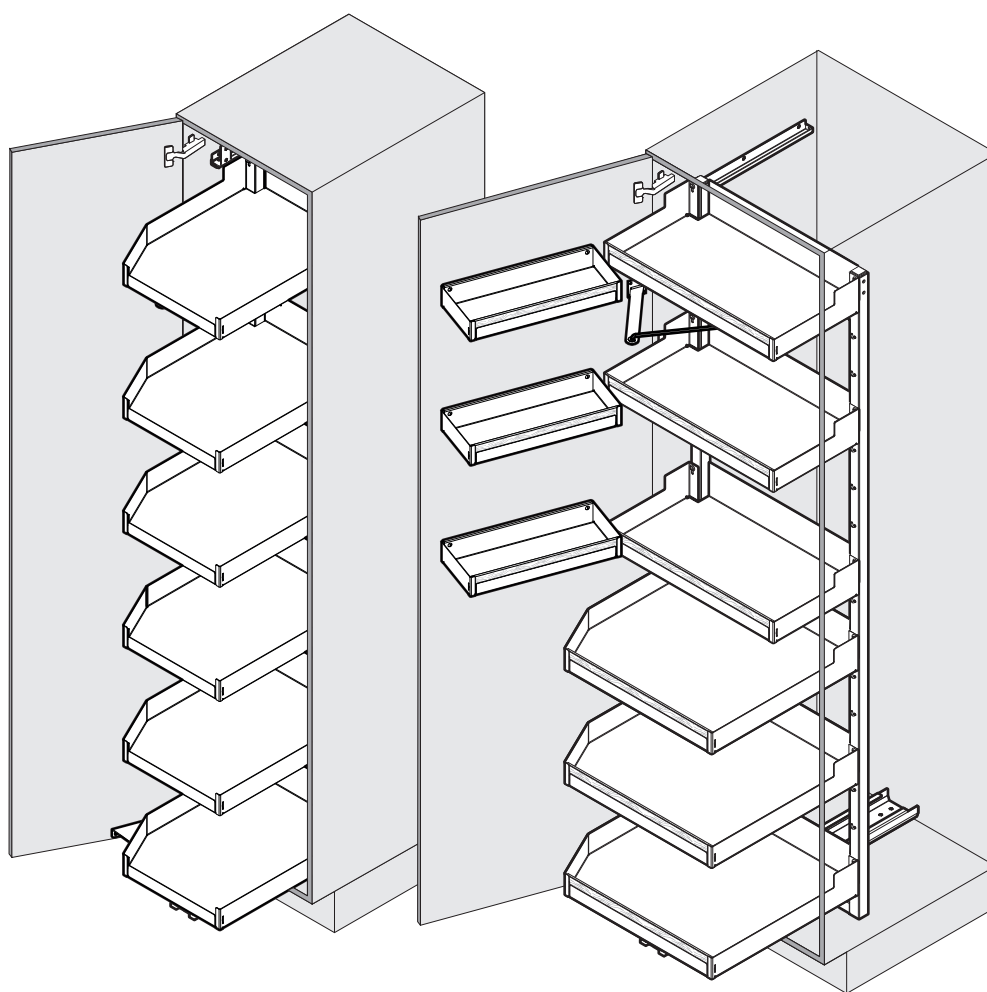

Art.Nr.

1300 / 450
100.1214.xx

1300 / 600
100.1215.xx

1600 / 450
100.1216.xx

1600 / 600
100.1217.xx

1900 / 450
100.1218.xx

1900 / 600
100.1219.xx

						Option	
1x 	1x 	1x 	1x 	1x 	1x 	1-6x 	1-6x
1x 	1x 	2x 	2x 	2x 	4x 	1-6x 	1-6x

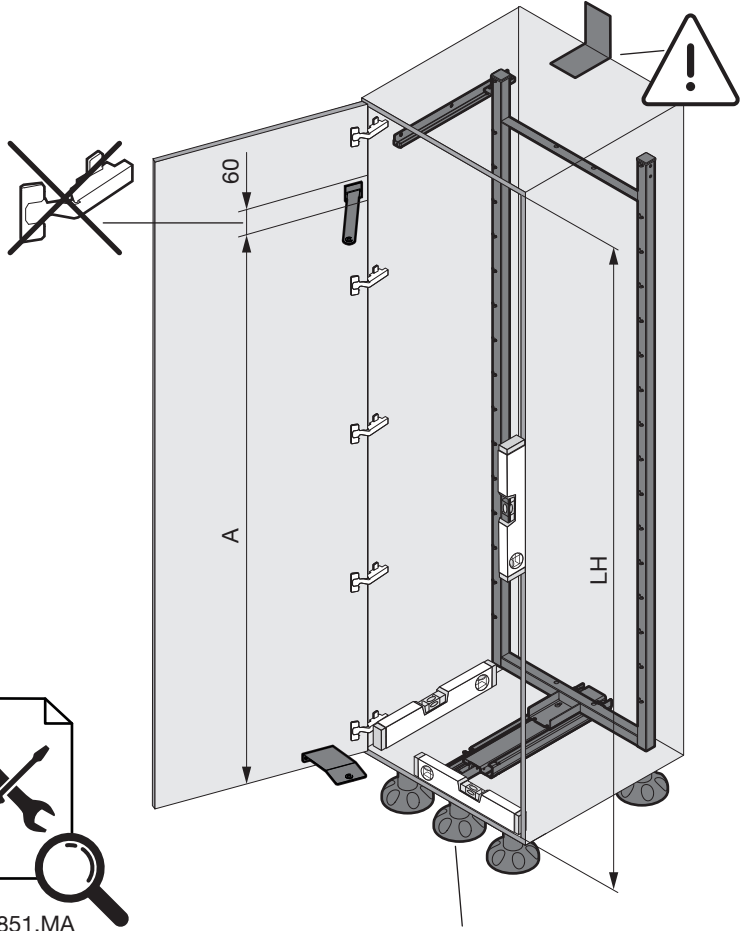
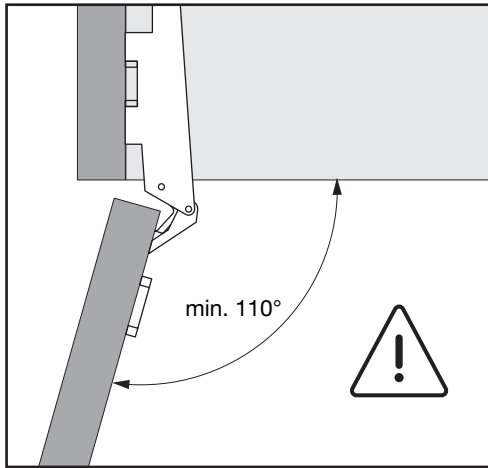

	A	min. LH
1300	944	1150
1600	1247	1450
1900	1600	1800

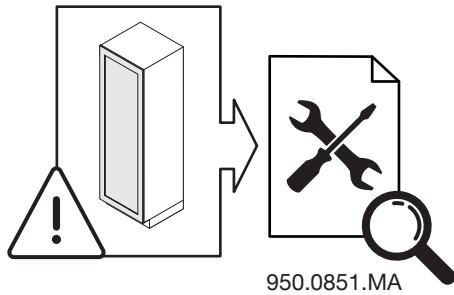

950.0851.MA

DE Links ausschwenkbar dargestellt, rechts ausschwenkbar spiegelbildlich.
FR Imagé est pivotant à gauche, pivotant à droite est inversée.
EN Left swivelling pictured, right swivelling is reversed image.

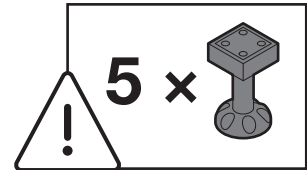

Pleno Maxi Standard



Σ = MAX. 78 kg

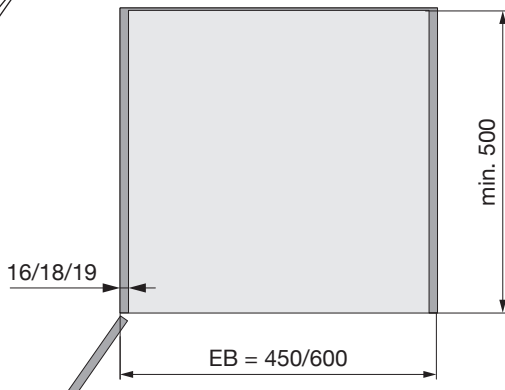
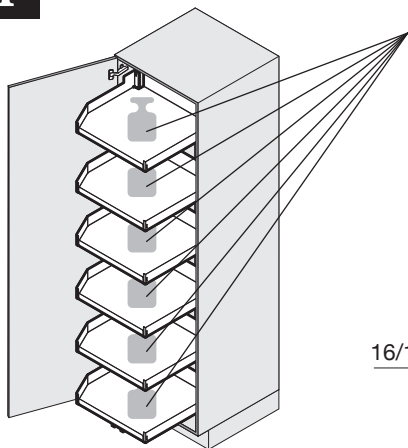

1300	2x
1600	3x
1900	3x

DE Links ausschwenkbar dargestellt, rechts ausschwenkbar spiegelbildlich.
FR Imagé est pivotant à gauche, pivotant à droite est inversée.
EN Left swivelling pictured, right swivelling is reversed image.

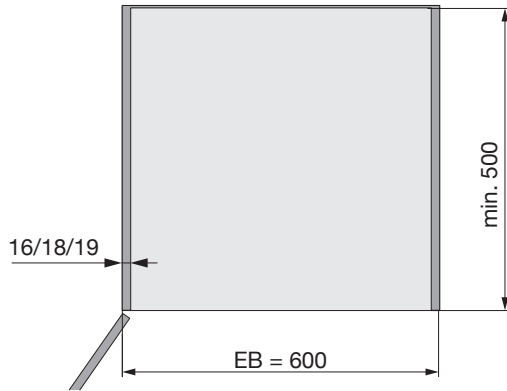
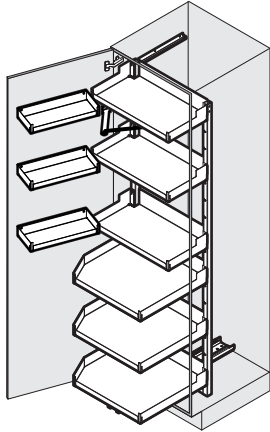



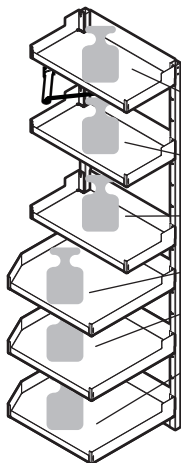
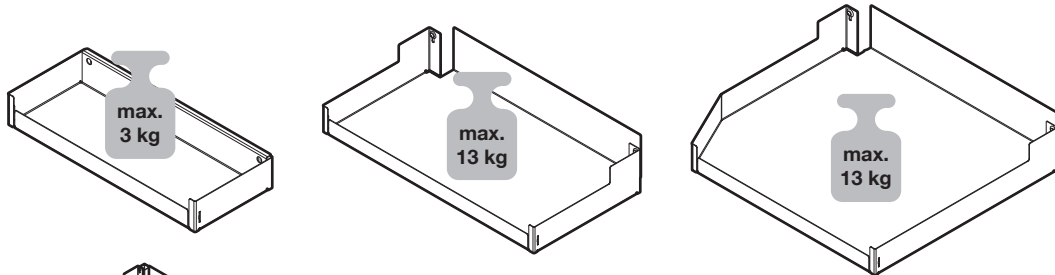



1300	2x	2x	2x	3x
1600	2x	2x	3x	4x
1900	3x	3x	3x	5x



$\Sigma = \text{MAX. 78 kg}$

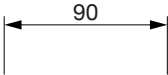

DE Links ausschwenkbar dargestellt, rechts ausschwenkbar spiegelbildlich.
 FR Imagé est pivotant à gauche, pivotant à droite est inversée.
 EN Left swivelling pictured, right swivelling is reversed image.

	Symbole	Symboles	Symbols
	Warnung	Avertissement	Warning
	Korrekt	Correct	Correct
	Nicht korrekt	Incorrect	Incorrect
	Lösen/gelöst	Détacher/détaché	Release/Released
	Fixieren/fixiert	Fixer/fixé	Secure/Secured
	Klick-Geräusch beim Einrasten	«Clic» lors de l'encliquetage	Audible click on engagement
	Alle Masse in mm	Toutes les dimensions en mm	All dimensions in mm



DE Die Gewichts- und Beladungsangaben gelten als Maximalwert und sind abhängig von den gewählten Schrankmaterialien (ein verwindungsteifes Material - z.B. Massivholz, Spanplatten - ist zu wählen) und der Schrankkonstruktion und können dementsprechend variieren!
Es wird davon ausgegangen, dass geeignete Verbindungs- und ggf. Konstruktionshilfsmittel (z.B. Stützen) eingesetzt werden. Eine verbindliche Beladungsangabe obliegt dem Verarbeiter!
Die technischen Darstellungen und Massangaben - auch Abbildungen und Zeichnungen - sind unverbindlich. Konstruktionsverbesserungen sind vorbehalten!

FR Les indications relatives au poids et à la charge servent de valeurs maximales, dépendent des matériaux choisis pour l'armoire et sa structure (choisir un matériau résistant à la torsion, p. ex. bois massif, panneau d'agglomérés), et peuvent varier en conséquence !
On suppose que des éléments de liaison et de structure appropriés (p.ex. des supports) sont utilisés.
Le responsable de la transformation du meuble est tenu de définir lui-même les valeurs de la charge !
Les illustrations technique et les cotes - y compris sur les schémas et les dessins - sont non contractuelles.
Sous réserve d'améliorations de la construction !

EN The weight and load specifications are given as maximum values and depend on the selected cupboard materials (a warp resistant material, such as solid wood or chipboard, should be chosen) and cupboard design so they may vary accordingly!
It is assumed that suitable fasteners and, if required, construction hardware (e.g. supports) will be used.
The fabricator is responsible for binding load specifications!
Technical information and stated dimensions (including in illustrations and drawings) must not be regarded as binding.
Design subject to change without notice (in interest of improvement)!

1

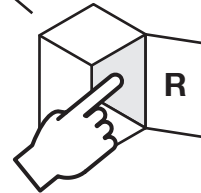
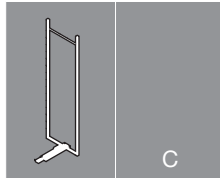
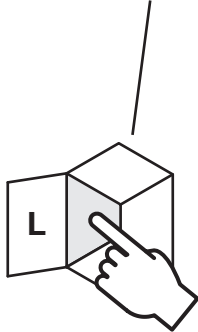
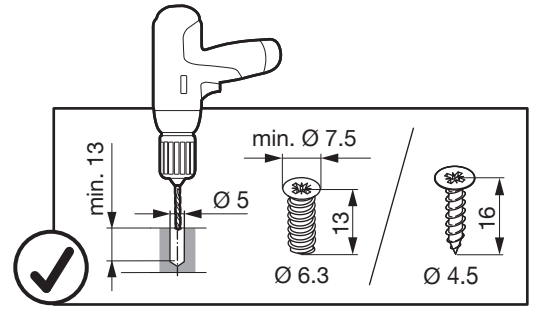
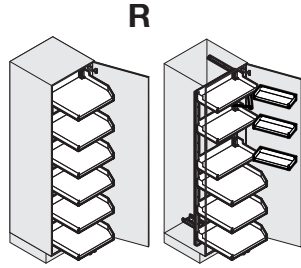
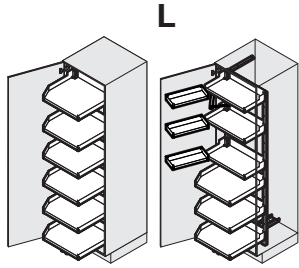
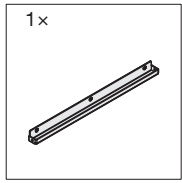

1300	1037
1600	1340
1900	1693

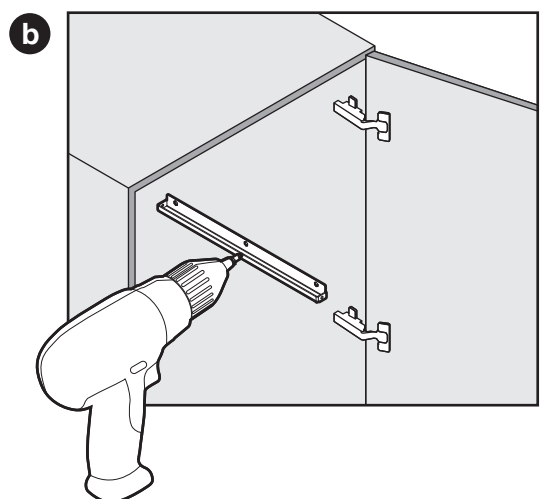
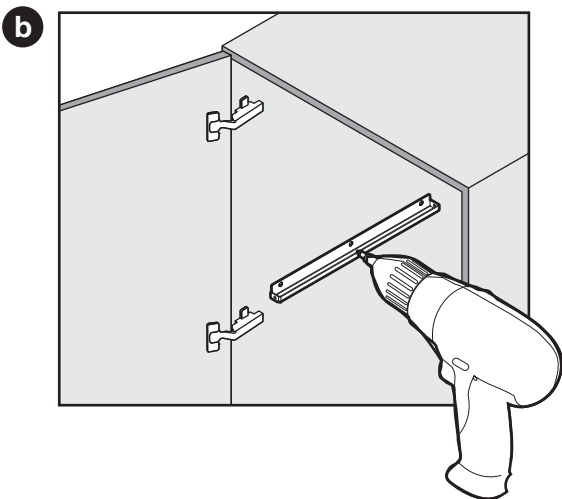
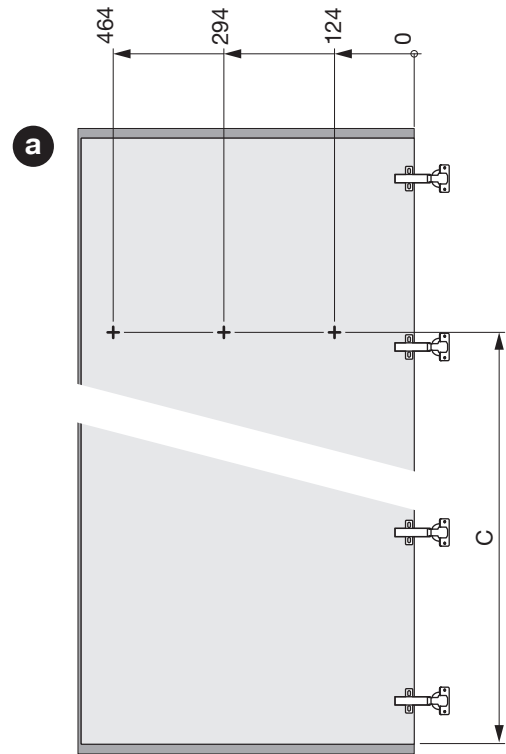
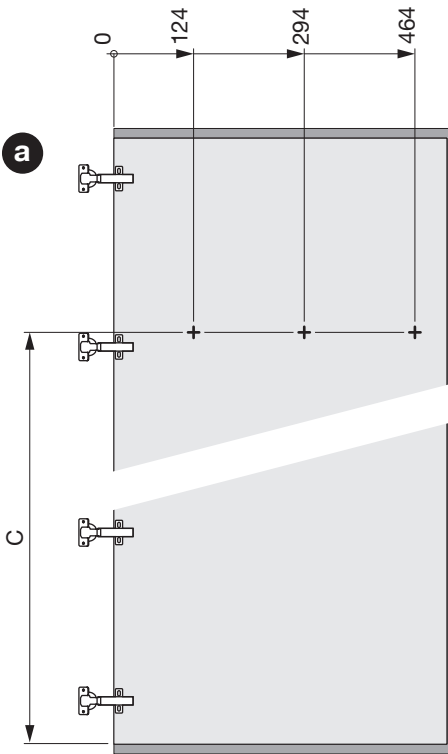

2

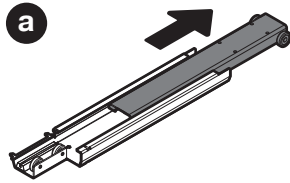
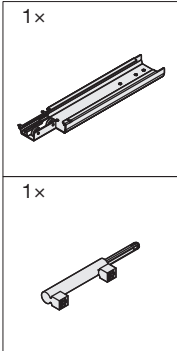

! DE Schmierfett nicht entfernen
FR Ne pas enlever la graisse
EN Do not remove grease

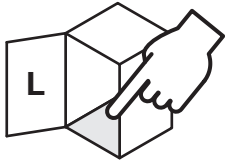
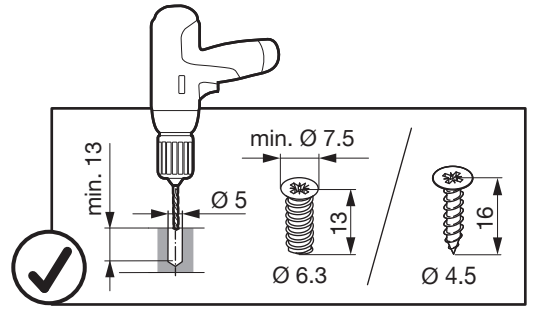

EB	D
450	198
600	273

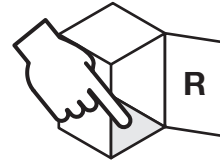

b

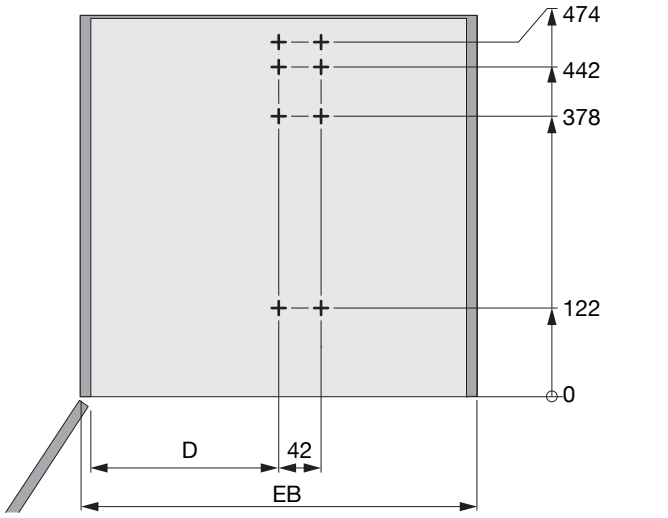

b

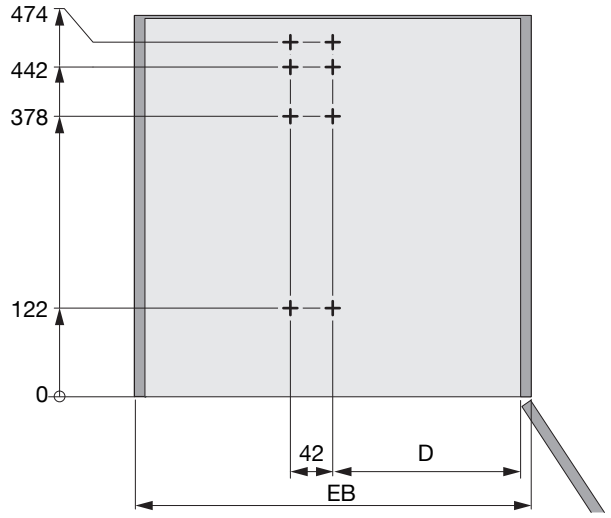

c

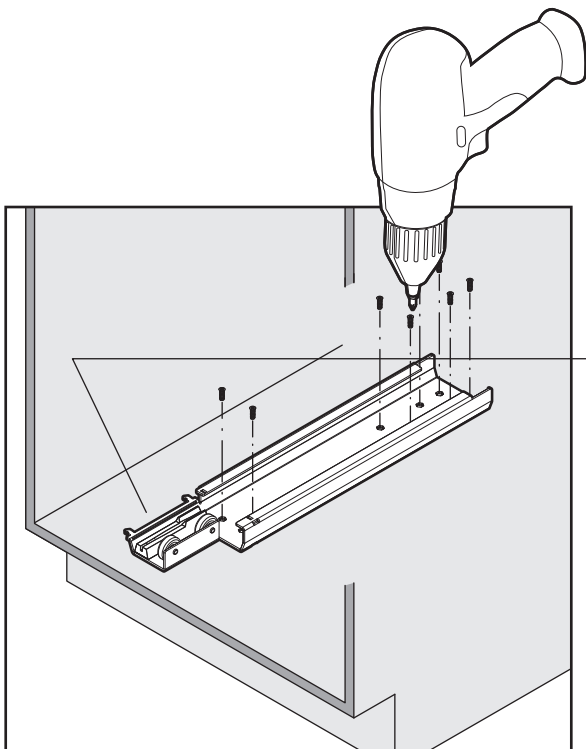

d

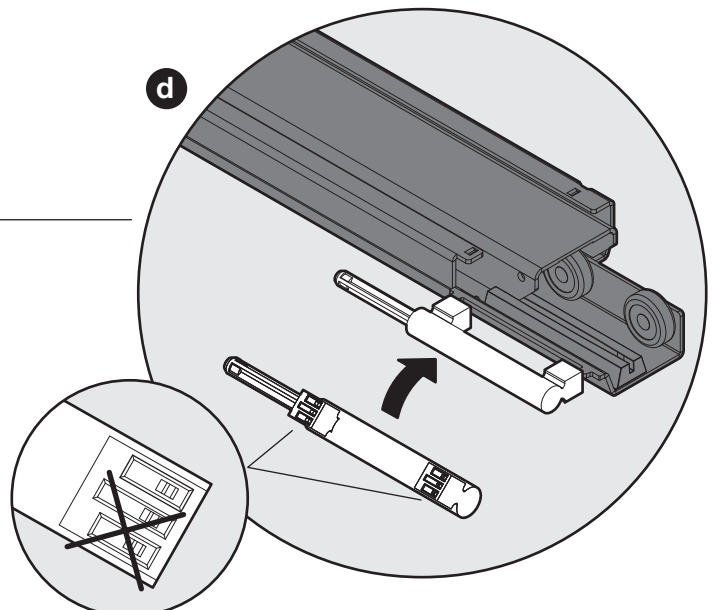

3

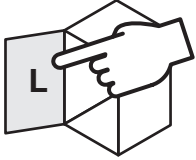
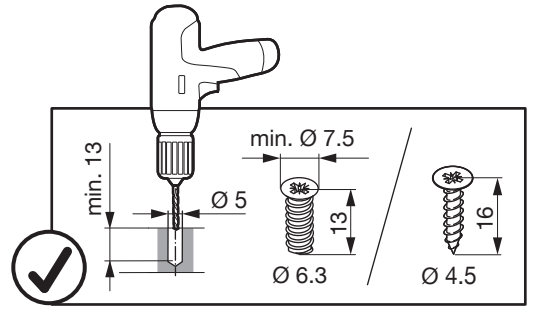
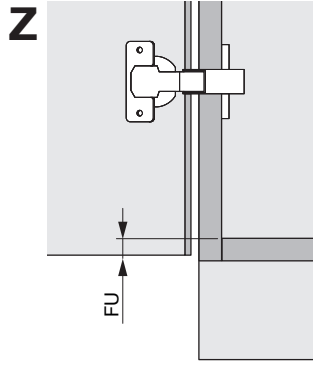
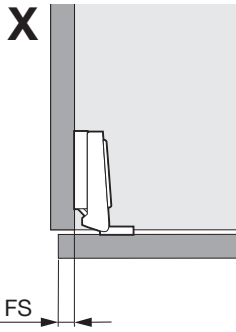
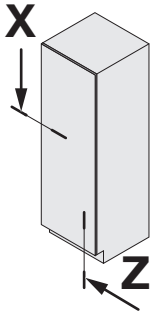

18 14 10 + FS

E	
1300	959
1600	1262
1900	1615

10 + FS 14 18

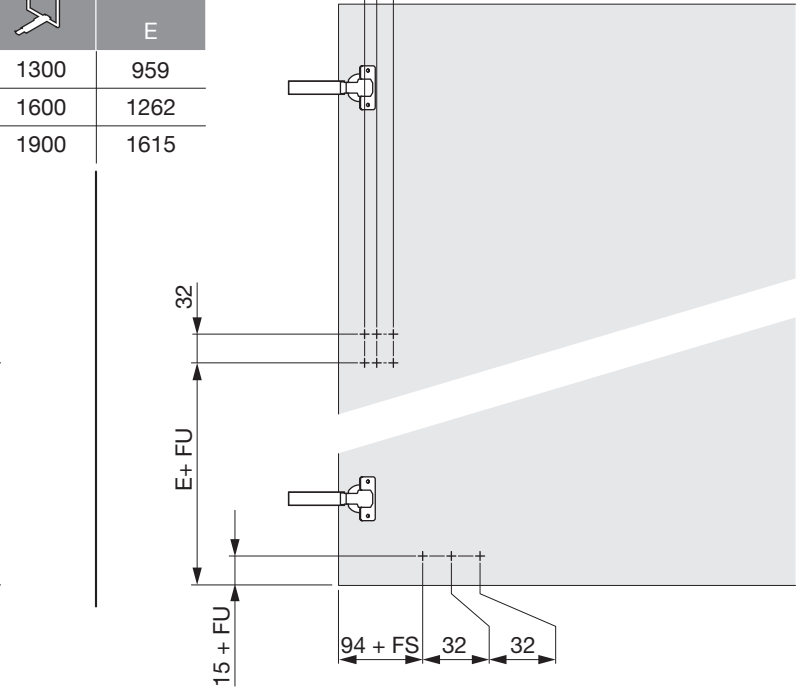
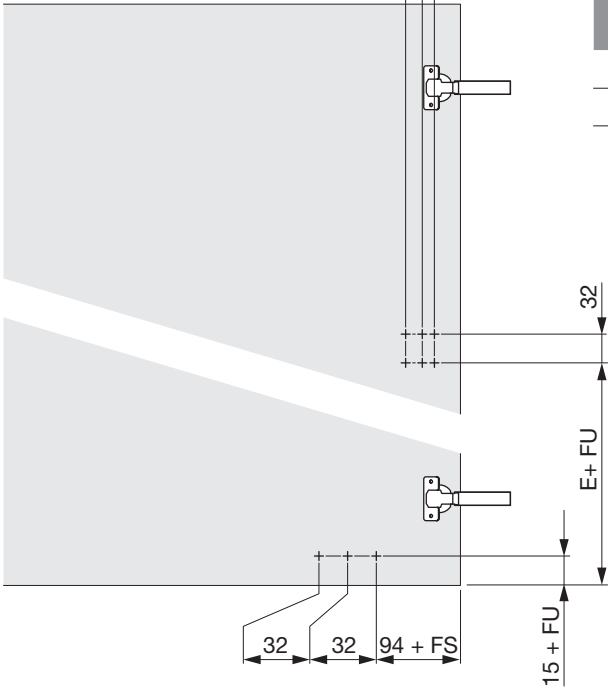
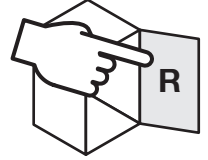

4

- 1x
- 1x
- 1x

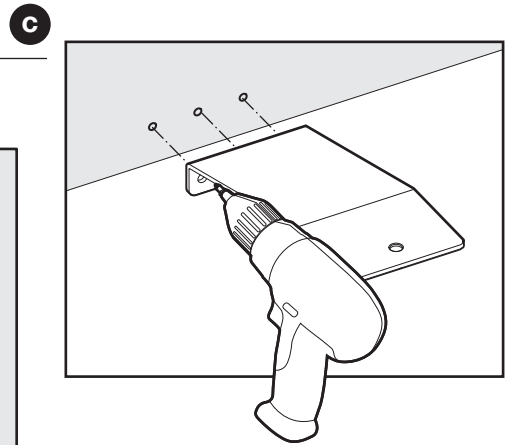
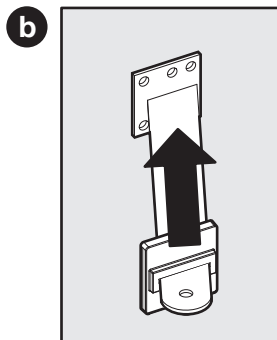
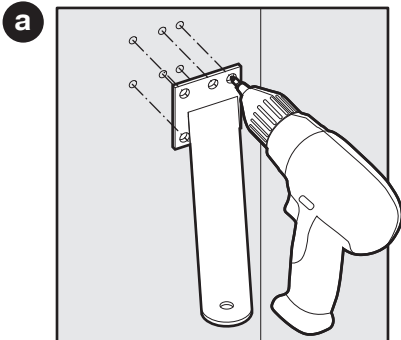
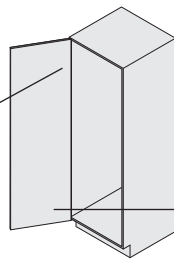

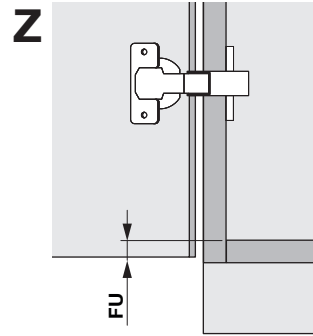
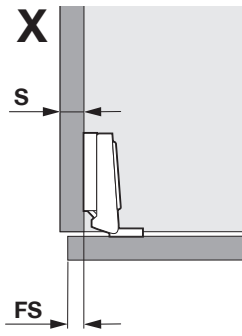
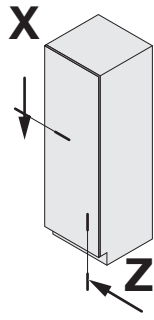

S	G
16	158 + FS
18	156 + FS
19	155 + FS

	I	J	K
1300	749 + FU	304	-
1600	1053 + FU	304	-
1900	1053 + FU	304	354

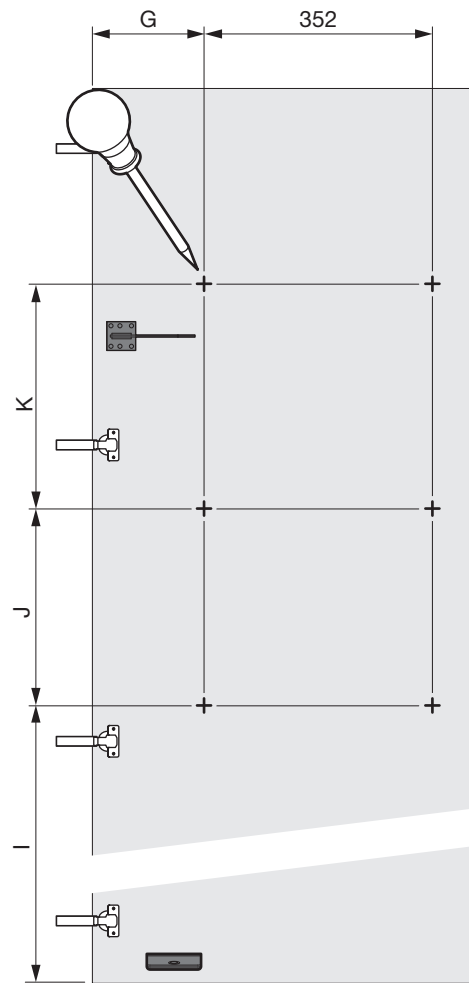
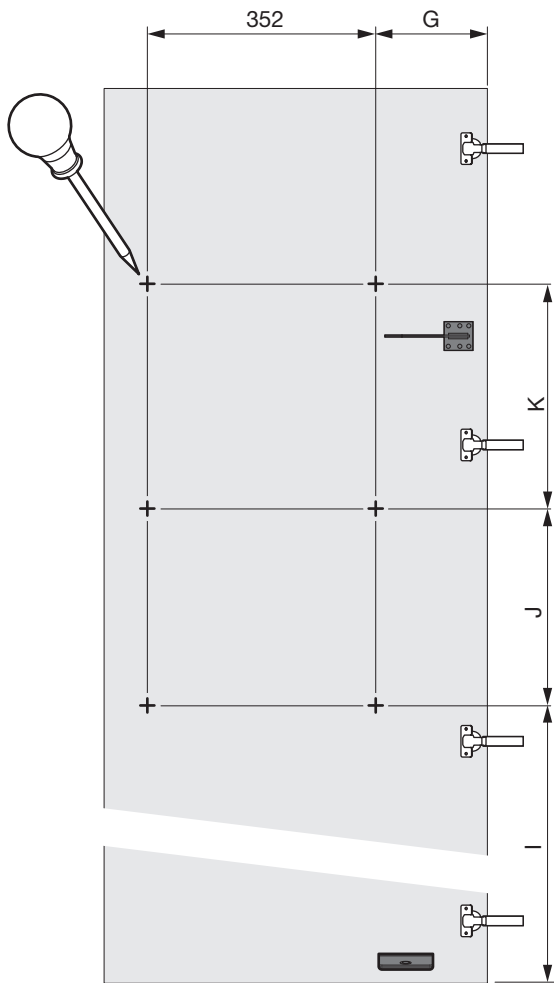
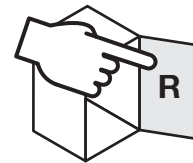
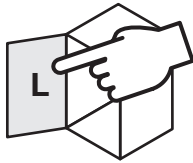

Pleno Maxi Plus

4-6x

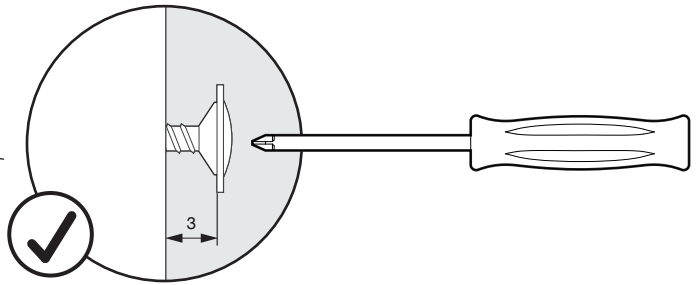
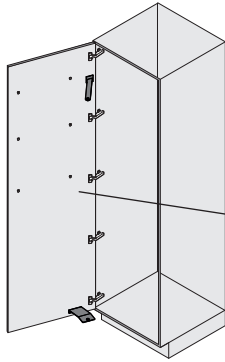

5

1x

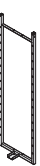

1x

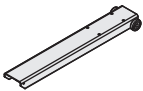

1x



2x



M5x10

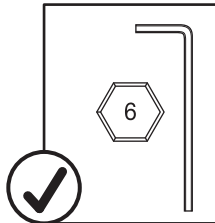

!
DE Schmierfett nicht entfernen
FR Ne pas enlever la graisse
EN Do not remove grease

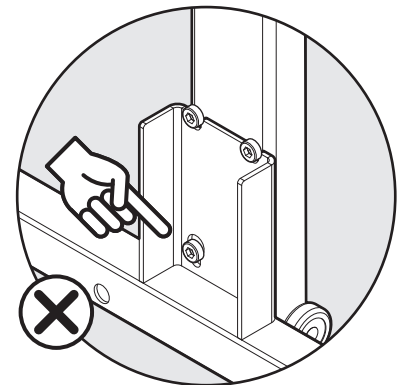
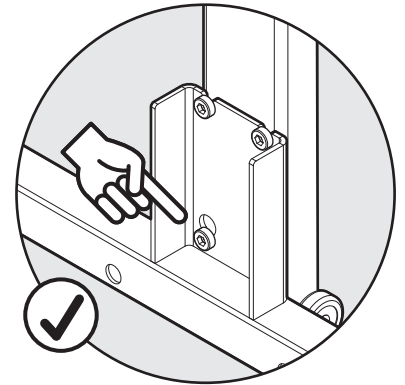
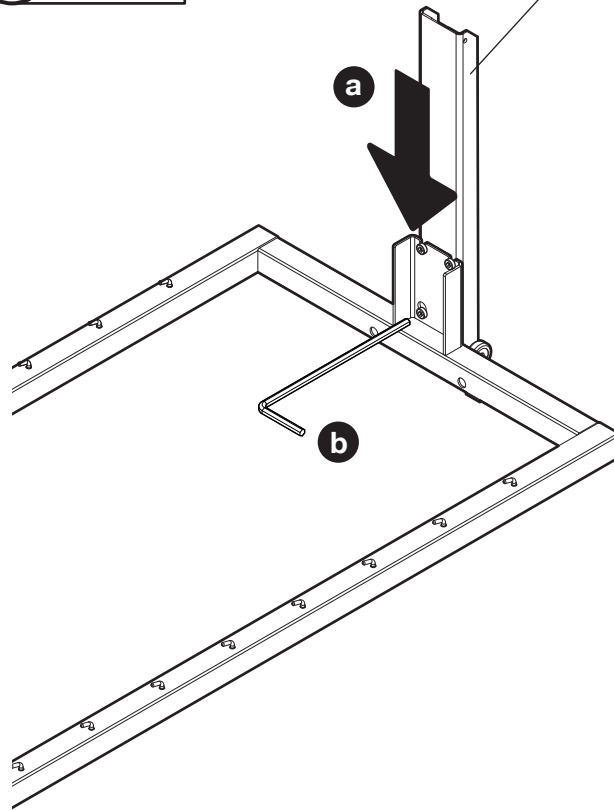

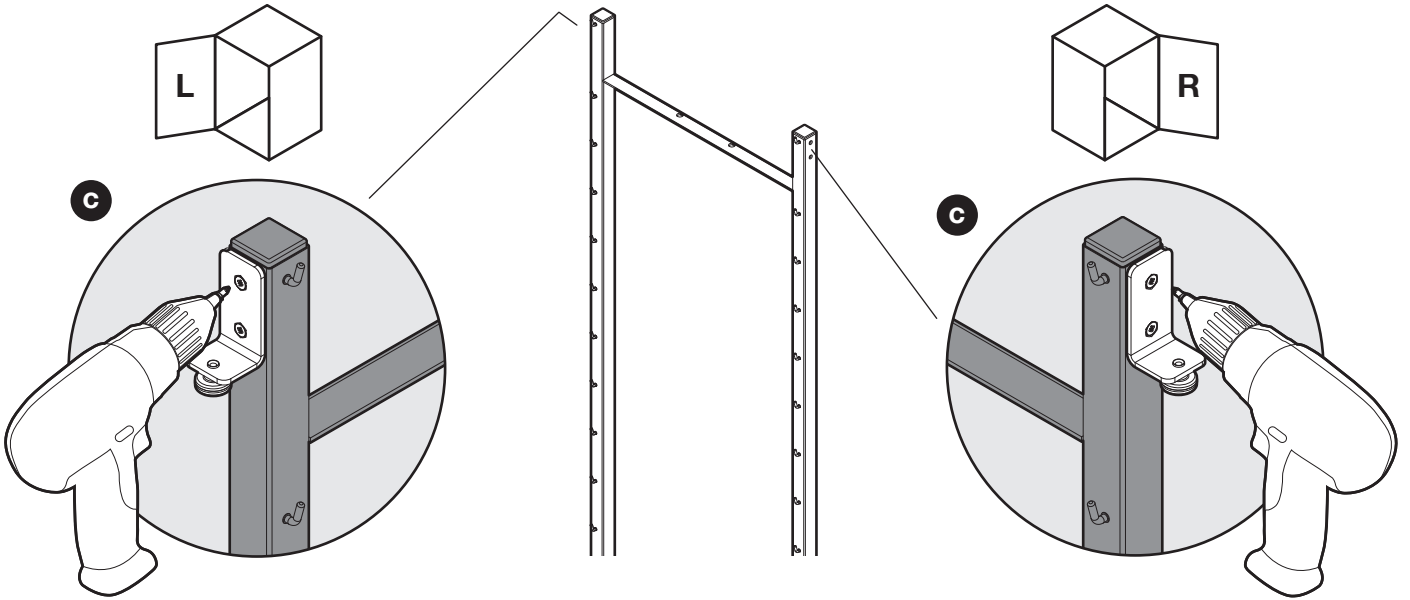

6

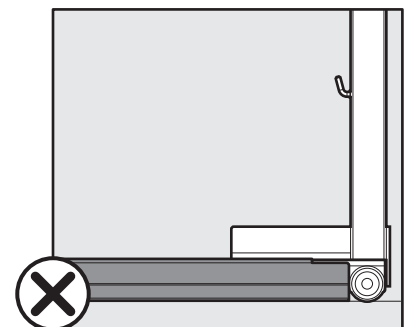
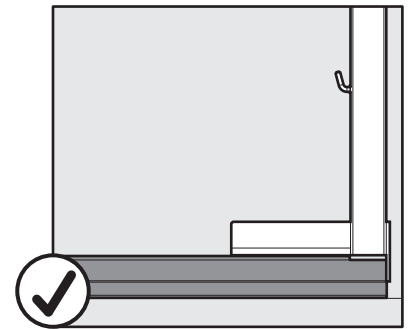
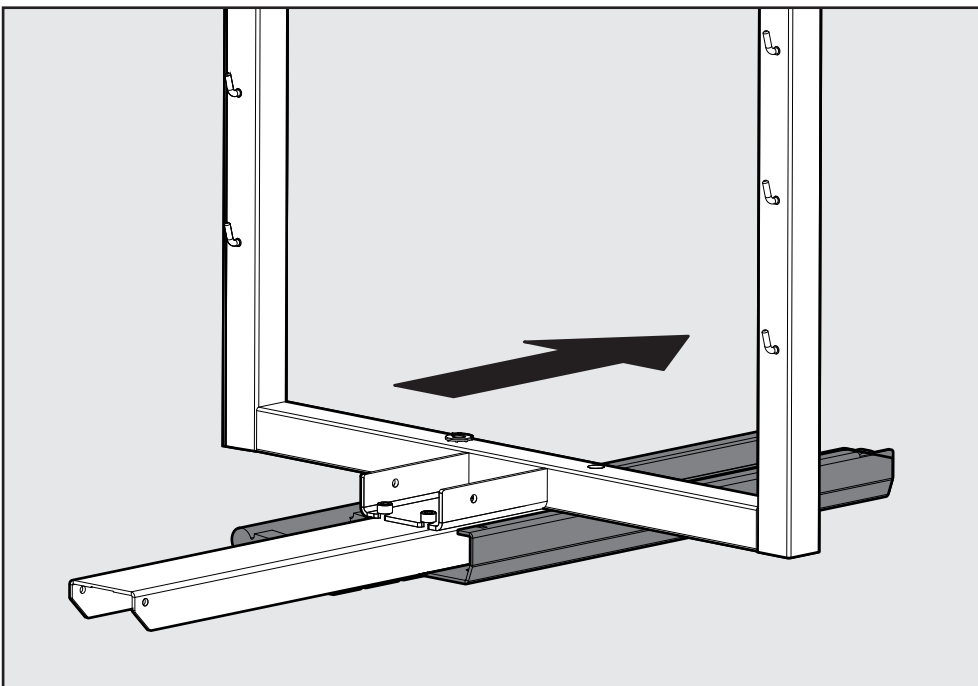
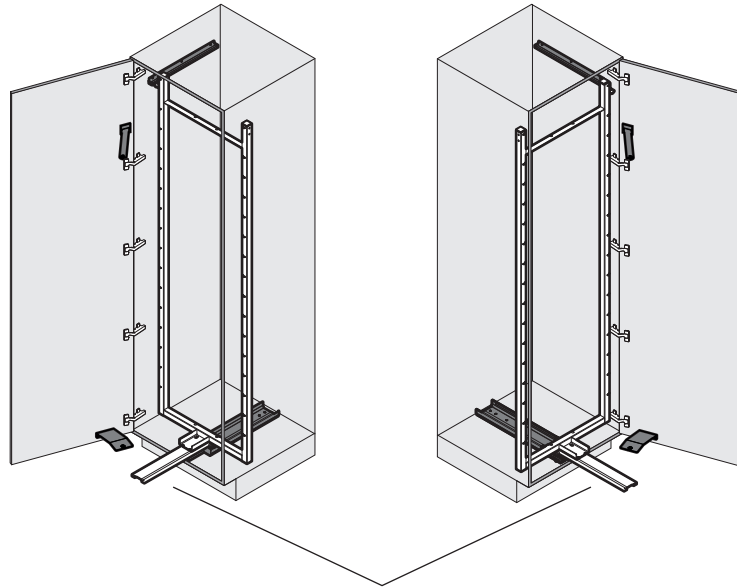

7

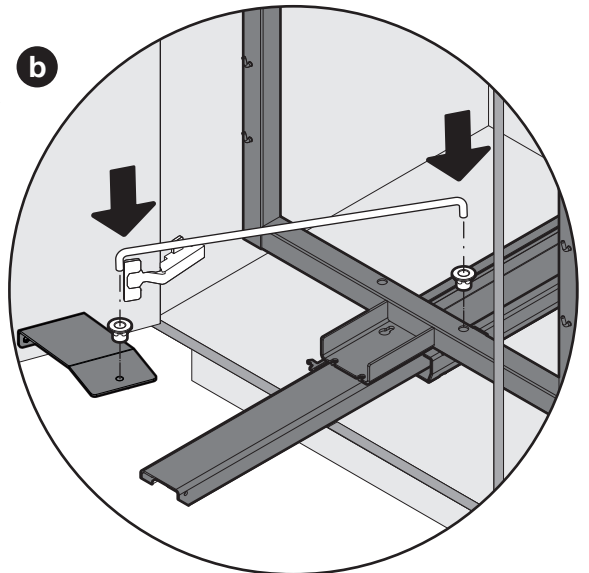
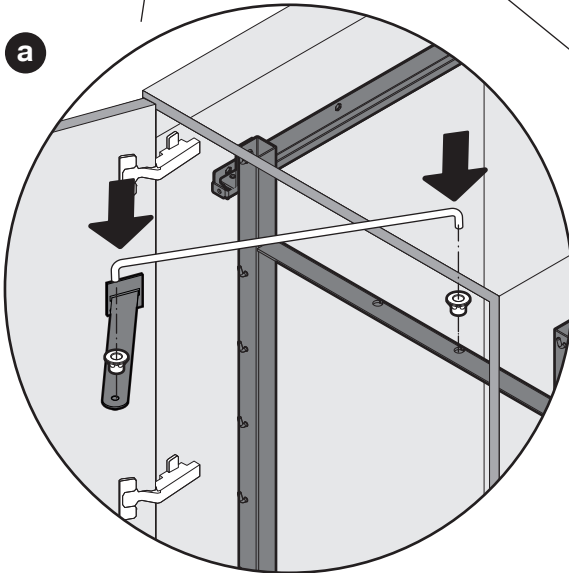
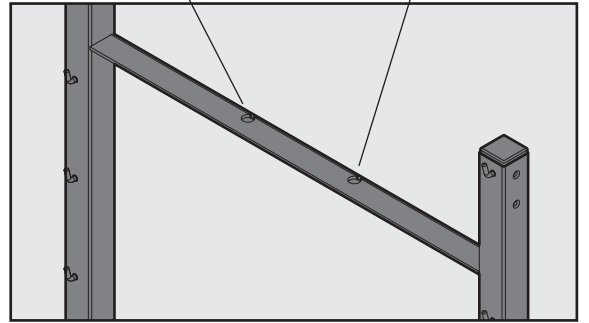
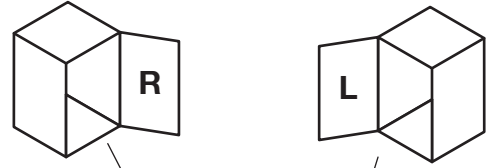
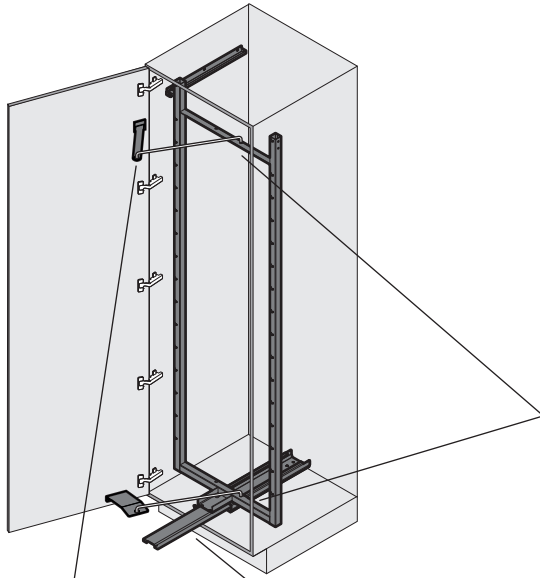
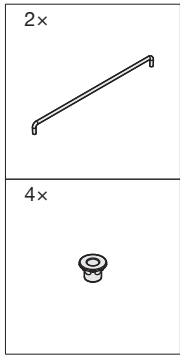

Pleno Maxi Plus

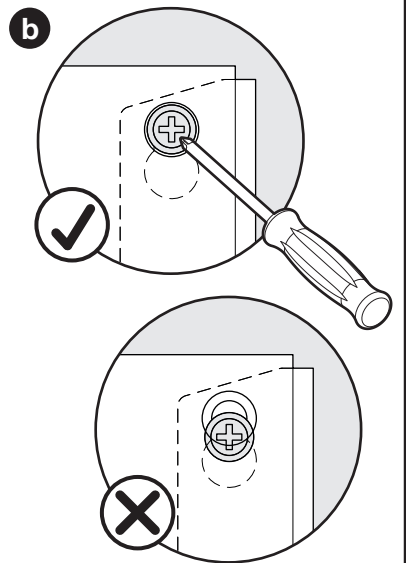
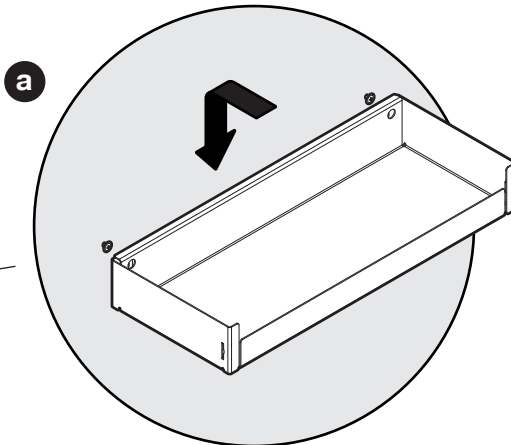
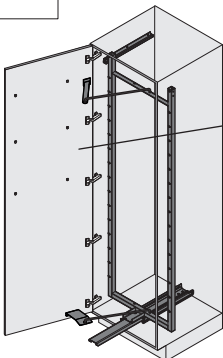
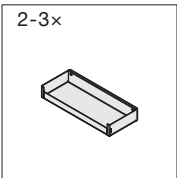

8

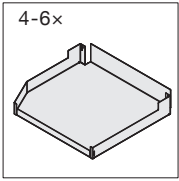

Pleno Maxi Standard

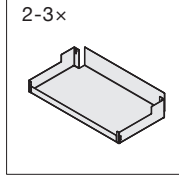
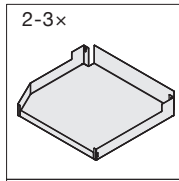
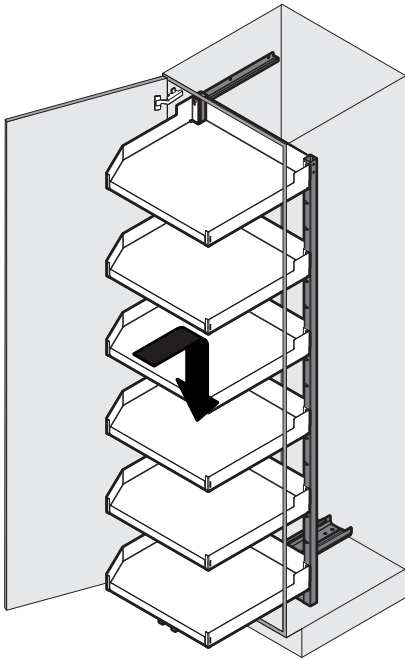

Pleno Maxi Plus

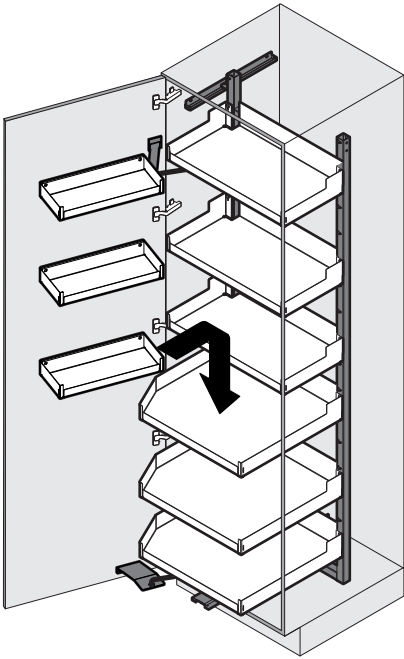

Option

